

WHITES

TOTALTILT



WHITES MATERIAL HANDLING
17 - 19 EMERY ROAD
BRISTOL
BS4 5PF
0117 972 0006
WWW.WHITESMH.CO.UK
SALES@WHITESMH.CO.UK



WHITES

FEATURES

Raex[®]

ABRASION
RESISTANT STEEL

- Variable pin centres allow the use of a wide range of OEM attachments
- ISO13031 compliant
- Zero maintenance required
- HKS actuator – world renowned quality
- RAEX high tensile steel base plates
- Unique removable hydraulic cylinder and guards
- Tailored hydraulic fitting kits available to suit the host machine
- Compact design – no external cylinders
- Tilt through 180° – maximum versatility

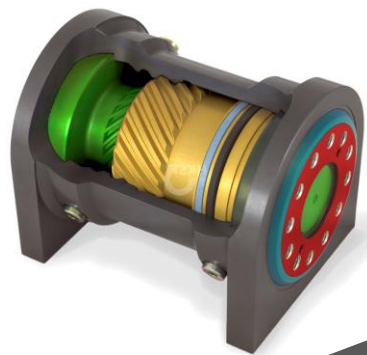

TOTALTILT

WHITES MATERIAL HANDLING
17 - 19 EMERY ROAD
BRISTOL
BS4 5PF
0117 972 0006
WWW.WHITESMH.CO.UK
SALES@WHITESMH.CO.UK

BENEFITS

Conventional models

Protruding, obstructive cylinders. Problems with excavating

Damage to the cylinders caused by soil, stones and dirt

Continuous re-lubrication/greasing of the cylinder bearing necessary

Bearings susceptible to maintenance

Restricted tilt angle and angle-dependent tilt torque

Minimum working width

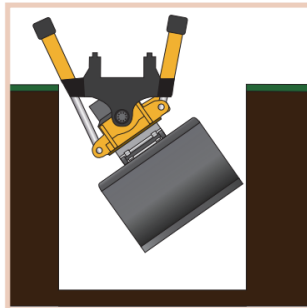
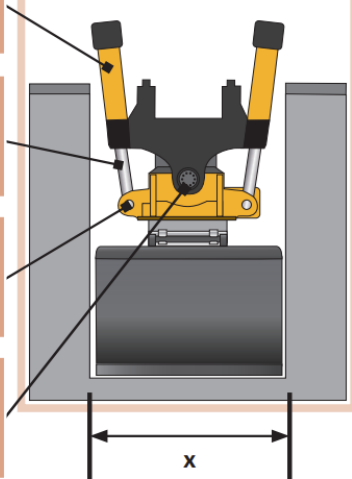

WHITES

BETTER WITHOUT CYLINDER



Minimum working width

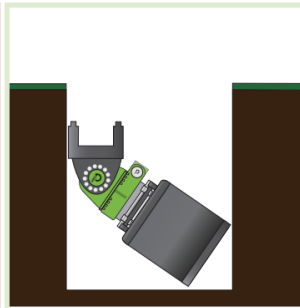
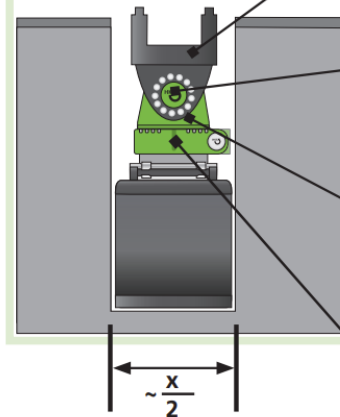

Narrower installation width. compact. robust. not sensitive to dirt. powerful

Greater accessibility thanks to greater tilt angle

Lower maintenance costs due to longer service intervals

Maintenance-free. strong friction bearings

Constant tilt torque. regardless of tilt angle

WHITES MATERIAL HANDLING
 17 - 19 EMERY ROAD
 BRISTOL
 BS4 5PF
 0117 972 0006
 WWW.WHITESMH.CO.UK
 SALES@WHITESMH.CO.UK

MODELS

WHITES

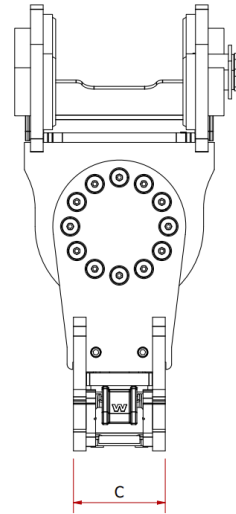
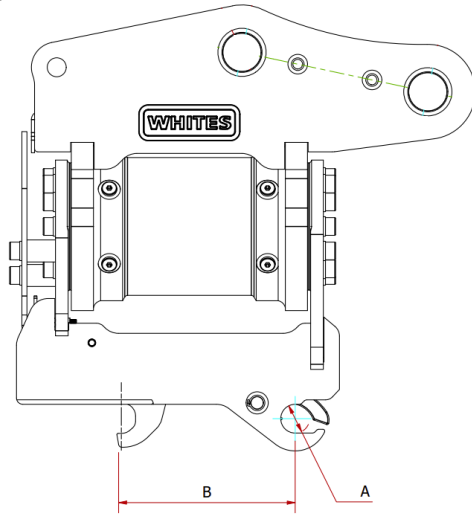

Part No.	Machine Capacity	Ø A	B	C
PT15	1.5 – 3.0 tonne			
PT30	4.0 – 5.0 tonne			
PT50	5.0 – 6.0 tonne			
PT80	7.0 – 9.0 tonne			
PT130	13.0 – 15.0 tonne			
PT210	21.0 – 23.0 tonne			

TOTALTILT

WHITES MATERIAL HANDLING
17 - 19 EMERY ROAD
BRISTOL
BS4 5PF
0117 972 0006
WWW.WHITESMH.CO.UK
SALES@WHITESMH.CO.UK